

KN-40

Category II or Category IV Appliance
(see Installation and Operation Manual for venting information)

CODE OPTIONS

CSD-1	STANDARD
-------	----------

INDOOR UNIT

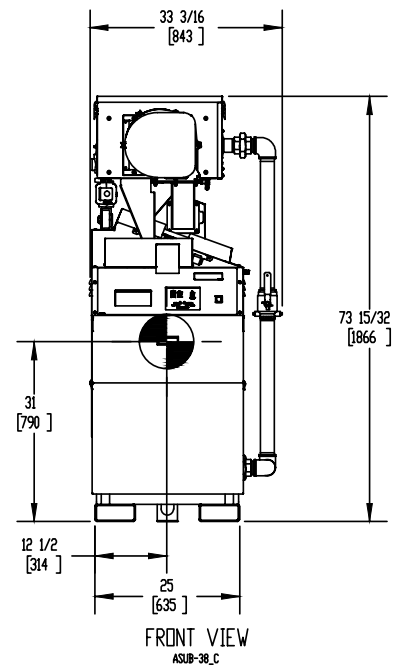
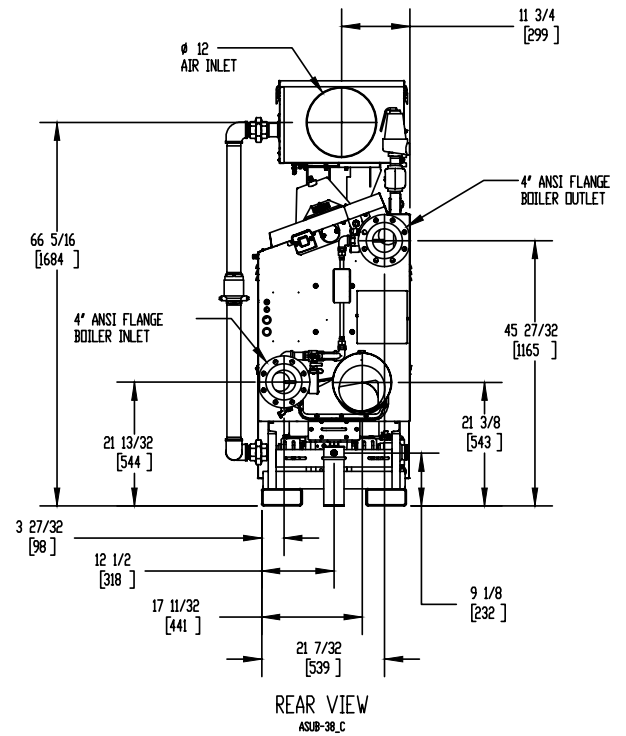
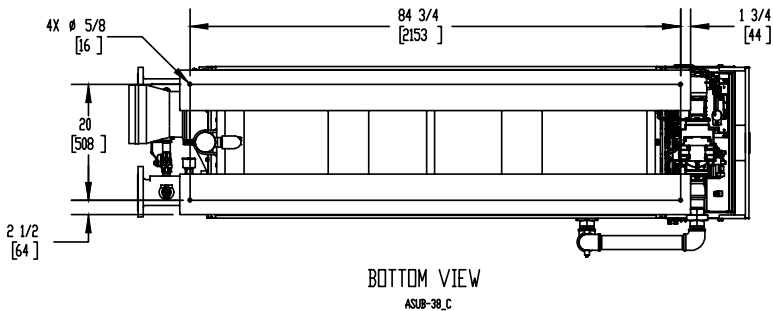
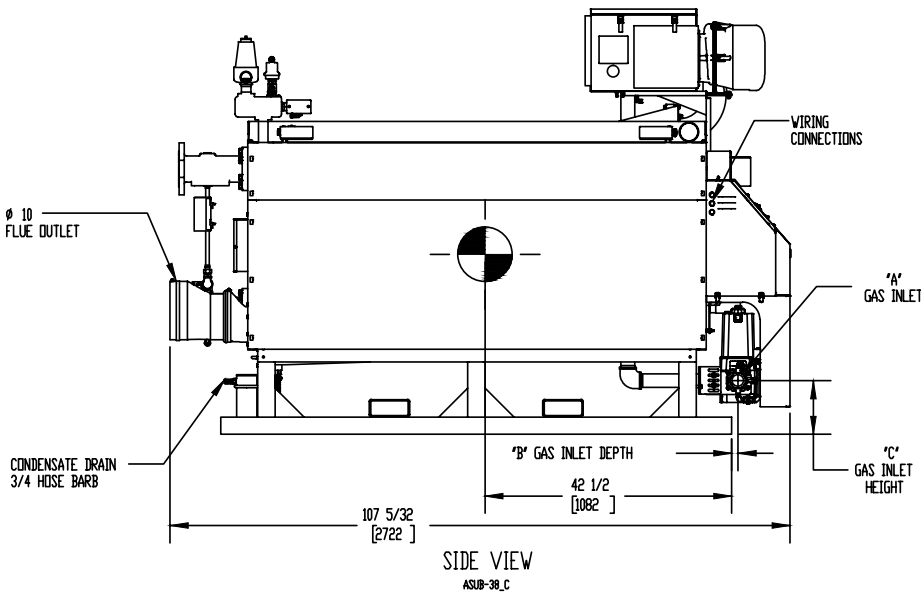
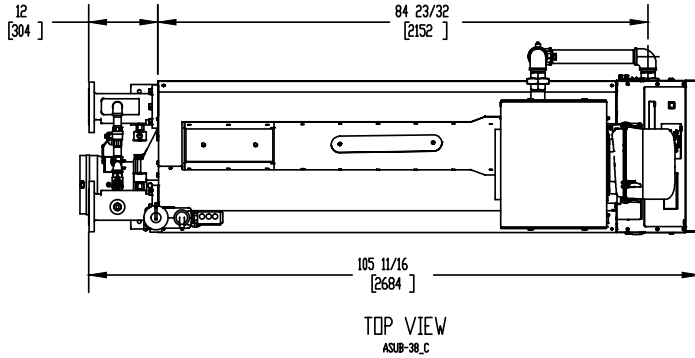

NOTES:

1. SYMBOL INDICATES CENTER OF GRAVITY.
2. DIMENSIONS ARE NOMINAL AND SUBJECT TO MANUFACTURING VARIATION AND SHOULD NOT BE USED FOR "ROUGHING IN".
3. ALL DIMENSIONS ARE INCHES (mm).

GAS OPTION	"A"	"B"	"C"
NG	2 NPT	1 1/8 [29]	9 3/32 [230]
LP	1 1/2 NPT	1 25/32 [45]	15 29/32 [404]



A.G.A. CERTIFIED RATINGS & CAPACITIES

Fuel Type	Natural/LP Gas	Boiler FLA	14.9 A*
Input BTU/hr.	4000 MBH / 1172 KW	Min. Gas Pressure Required	3" W.C.
Output BTU/hr.	3540 MBH / 1037 KW	Max. Gas Pressure Allowed	14" W.C.
Boiler HP	105.8	Water Volume	41.6 gal.
Electrical Requirements	230VAC/60 hz/3PH	Operating Weight	4627 lbs. / 2101 kg.
SCCR Rating	5kA		

BOILER TRIM & CONTROLS

Main Gas Valve	Dungs MBC	Air Switch	Huba
Firing Valve	2" Apollo	Flow Sensor	SIKA
Ignition Control	Honeywell RM7895C	Blocked Flue Switch	Cleveland NS2
Operating Control	HeatNet®	Blower Motor	Ametek
High Limit (Manual Reset)	Honeywell L4006E	L.W.C.O.	800
High Limit (Auto Reset)	Honeywell L4006A	Relief Valve	30, 50, 75 & 100 PSI
Main Ball Valve	2" Apollo	Pilot Regulator	Maxitrol RV12LT
Pilot Cock	1/4" Conbraco		

A.S.M.E.

ASME Sect IV Fire Side Htg Surface	139.63 Sq. Ft. / 12.97 Sq. M.	Design Data	100 PSI & 250°F
ASME Sect IV Water Side Htg Surface	149.29 Sq. Ft. / 13.87 Sq. M.		
CV. GPM (1PSID)	271		

*Add circulator amps.

TEMPERATURE RISE / PRESSURE DROP (Based on Full Input)

20°F / 11.1°C				40°F / 22.2°C				60°F / 33.3°C				80°F / 44.4°C				100°F / 55.5°C			
Flow Rate		Pressure Drop		Flow Rate		Pressure Drop		Flow Rate		Pressure Drop		Flow Rate		Pressure Drop		Flow Rate		Pressure Drop	
GPM	L/s	Ft	kPa	GPM	L/s	Ft	kPa	GPM	L/s	Ft	kPa	GPM	L/s	Ft	kPa	GPM	L/s	Ft	kPa
354.1	22.3	3.94	11.8	177.1	11.2	.99	2.90	118.0	7.40	.44	1.30	88.5	5.60	.25	.70	70.8	4.50	.16	.50

Flow GPM				Temp. Rise** (°F)				Vent Length (Equiv. Ft.)				Air Inlet Length (Equiv. Ft.)			
Min		Max		Min		Max		Min		Max		Min		Max	
70.8		354.1		20		100		6		100		0		100	

**Min/Max delta t reflects boiler operation at full input. For applications requiring operation above/below these parameters please consult factory.

<p>REP FIRM _____</p> <p>SUBMITTED BY _____</p> <p>JOB NAME _____</p> <p>ARCHITECT _____</p> <p>ENGINEER _____</p> <p>CONTRACTOR _____</p> <p>DATE _____</p>	<div style="background-color: black; color: white; padding: 10px; font-size: 2em; font-weight: bold; margin-bottom: 10px;">KN-40</div> <p>Category II or Category IV Appliance (see Installation and Operation Manual for venting information)</p> <div style="display: flex; align-items: center; justify-content: center; margin-top: 20px;"> <div style="text-align: left;"> <p>A Division of Mestek, Inc. Westfield, MA 01085 (413) 564-5515</p> </div> </div>
---	---

KN-40

OUTDOOR UNIT

